

Product Information

VEGASWING for liquids

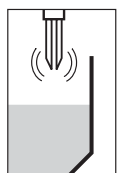
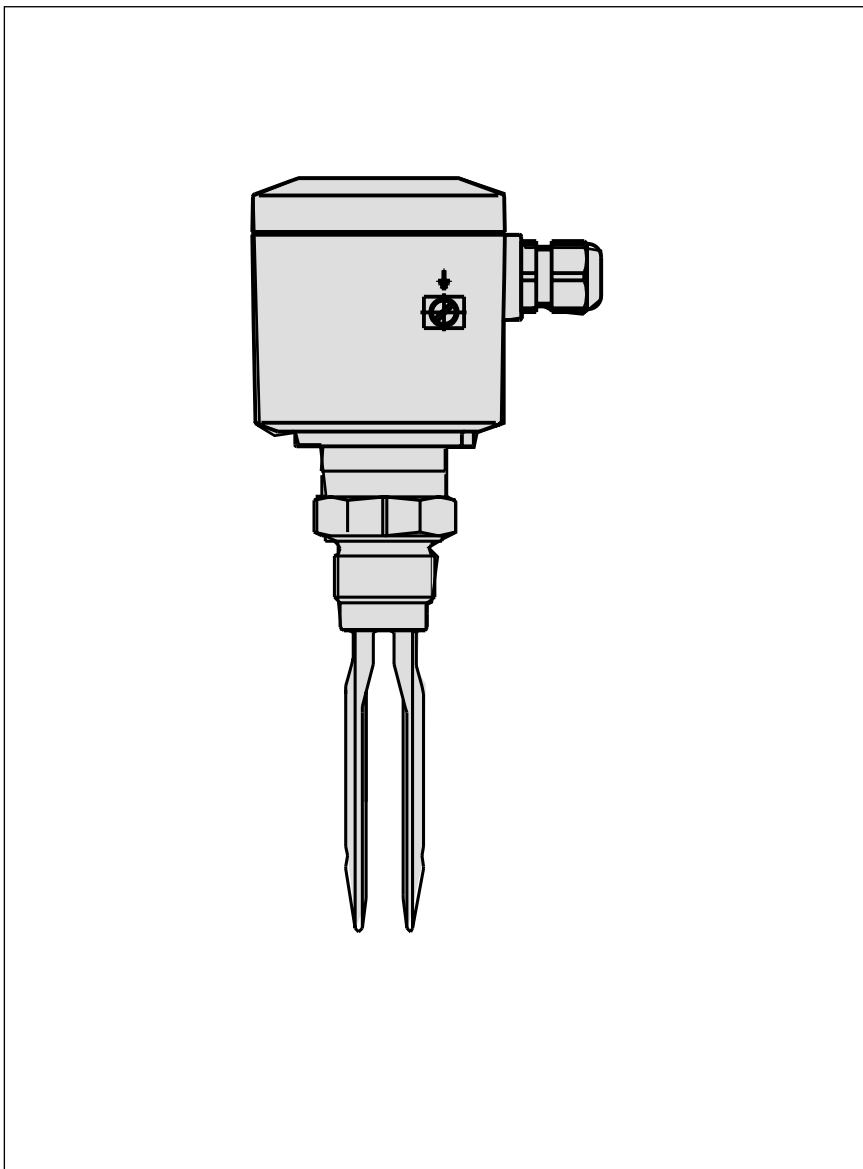

Contents

1	Product description	
1.1	General	3
1.3	VEGASWING series 80A	3
1.2	VEGASWING series 70A	3
1.4	Recurring test acc. to WHG	4
2	Function and application	
2.1	Principle of operation	5
2.2	Measuring system	5
3	Types and versions	
3.1	VEGASWING vibrating level switches - Overview	6
3.2	Technical data and dimensions	8
3.3	Technical data signal conditioning instruments and dimensions	21
3.4	Flanges	25
3.5	Application examples	27
3.6	Approvals	28
4	Electrical connection	
4.1	VEGASWING 71A/75A	29
4.2	VEGASWING 80A	30
4.3	Signal conditioning instruments series 500 and series 600	32

1 Product description

1.1 General

VEGASWING vibrating level switches detect levels of liquids.

The tuning fork of VEGASWING detects liquid levels. Typical applications are overflow protection and dry run protection of pumps. Vibrating level switches are available as compact instruments, i.e. with integrated processing or for connection to a signal conditioning instrument.

VEGASWING vibrating level switches detect liquid levels with a viscosity of 0.2 ... 10.000 mPa s and a density of $\geq 0.5 \text{ g/cm}^3$. Modular construction enables their use in vessels, tanks and pipelines. Typical applications are overflow and dry run protections.

Due to the simple and rugged measuring system, VEGASWING is virtually unaffected by the chemical and physical features of the liquid. It works even under unfavourable conditions such as turbulences, air bubbles, foam generation, buildup or varying products.

- integrated fault monitoring
- fixed, exactly reproducible switching point
- switching condition visible with closed instrument (LED)
- insensitive to buildup due to large gaps
- insensitive to external vibrations
- setup without adjustment
- compact
- individual installation position
- selectable min. or max. mode
- Operating pressure up to 40 bar

1.2 VEGASWING series 70A

VEGASWING 71A/75A vibrating level switches are especially suitable for tight installation conditions.

VEGASWING 75A is mainly suitable for level detection in the food processing and pharmaceutical industry. Due to the polished sensor surface ($R_a < 0.5 \mu\text{m}$ or $R_A < 1.5 \mu\text{m}$) bacteria have no chance to collect. VEGASWING 75A is also suitable for CIP and SIP cleaning.

Many different hygienic fittings such as conus with compression nut, Tri-Clamp 1 1/2" and 2", bolting, Tuchen-hagen Varivent or special hygienic connections are available.

- transistor output PNP/NPN selectable on oscillator
- permanently shortcircuit proof and overload resistant
- operating temperature from -40°C to $+150^\circ\text{C}$
- stainless steel housing protection IP 67
- simple electrical connection by plug connector

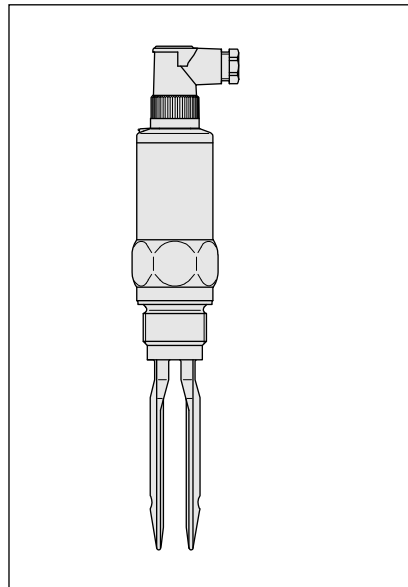

VEGASWING 71

1.3 VEGASWING series 80A

- Four different oscillators, relay output, contactless electronic switch, transistor output, two-wire output
- All standard mechanical connections possible, e.g. thread, flange, hygienic fittings etc.
- High resistance also available in aggressive products by using suitable materials such as e.g. enamel
- Protection IP 66
- Approvals acc. to PTB Zone 0 EEx ia IIC T6, CENELEC EEx ia IIC T6, WHG
- Suitable for foodstuffs

For use in very aggressive products, VEGASWING 81 A can be coated with ECTFE (Halar), Hastelloy or enamel or VEGASWING 83A can be coated with enamel and Halar up to 3000 mm or Säkaphen and Hastelloy C4.

For product temperatures up to 150°C VEGASWING 80A can be equipped with a temperature adapter.

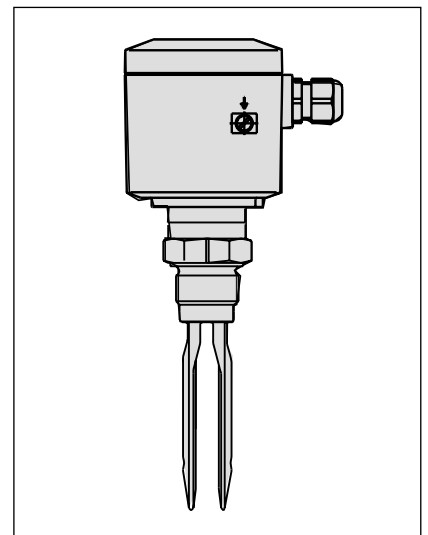

VEGASWING 81

1.4 Recurring test acc. to WHG

According to the type approval acc. to WHG (Z-65.11-154) the recurring test acc. to WHG can be carried out by pushing the test key on the VEGATOR 536 Ex, 537 EX, 636 Ex signal conditioning instrument. The sensor must neither be removed nor response triggered by filling the vessel. This is valid for VEGASWING 81A EX and 83A EX with two-wire oscillator SWING E82B EX.

In mode A (overflow protection) VEGASWING 81A EX and 83A EX meet the fail safe requirements acc. to class 3 (AK 1 ... 3) according to DIN 19 251.

2 Function and application

2.1 Principle of operation

VEGASWING vibrating level switches detect levels of virtually all liquids.

Measuring principle VEGASWING

The tuning fork is piezoelectrically energised and vibrates at its mechanical resonance frequency of approx. 400 Hz. When the tuning fork is submerged in the product, the frequency changes. This change is detected by the integrated oscillator and converted into a switching command.

The integrated fault monitoring detects:

- interruption of the connection cable to the piezo elements
- extreme abrasion on the tuning fork
- break of the tuning fork
- no vibration.

If one of the stated failures is determined or in case of voltage loss, the electronics takes a defined switching condition, i.e. depending on the electronics version

- the contactless electronic switch opens
- the relay deenergises
- the output transistor blocks.

With the two-wire output version the failure is signalled via a defined current to the connected VEGATOR signal conditioning instrument.

Compact instruments

All vibrating level switches are available as compact instruments, i.e. all instruments can be operated without external processing. The integrated electronics processes the level signal and makes an output signal (corresponding to the installed oscillator) available. With this output signal, a connected instrument can be directly operated (e.g. a warning system, a PLC, a pump etc.).

The installation of one of the following oscillators makes a compact instrument out of the vibrating level switch:

- contactless electronic switch (C)
- relay output (R)
- transistor output (T).

Vibrating level switch with signal conditioning instrument

Oscillator B (two-wire output) can be mounted in VEGASWING series 80A. The vibrating level switches can be then connected to a signal conditioning instrument. Depending on the requirements, there is a choice of the following signal conditioning instruments:

- VEGATOR 536 Ex
- VEGATOR 537 Ex
- VEGATOR 636 Ex

2.2 Measuring system

A measuring system with a vibrating level switch can be realized in two ways.

Level detection of liquids with compact instrument

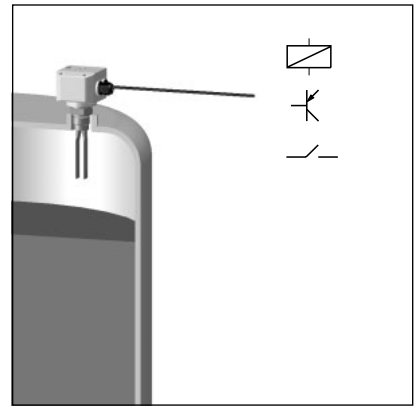

Measuring system with VEGASWING as compact instrument

A measuring system consists of:

- a VEGASWING vibrating level switch with integrated oscillator
- connected instruments operated with VEGASWING.

Level detection of liquids with signal conditioning instrument

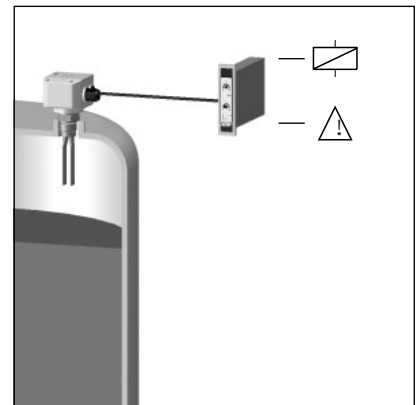

Measuring system with VEGASWING with separate processing

A measuring system consists of:

- a VEGASWING vibrating level switch with integrated oscillator
- a VEGATOR level switch or the VEGALOG processing system

3 Types and versions

3.1 VEGASWING vibrating level switches - Overview

	71A	75A	81A	83A	81A ExD	83A ExD
Version						
Standard (fixed installation length)	•	•	•		•	
Tube version				•		•
Approvals						
Ex-Zone 0 acc. to ATEX 100 a EEx ia IIC T6			•	•		
Ex-Zone 0 acc. to ATEX 100 a EEx d IIC T6					•	•
Overfill protection acc. to WHG		•	•	•	•	•
Mechanical connection						
G 1 A	•	•	•	•	•	•
1" NPT	•	•	•	•	•	•
Flange from DN 32, ANSI 2"			•	•	•	•
Tri-Clamp 1.5"		•	•	•		
Tri-Clamp 2"		•	•	•		
Conus DN 25		•	•	•		
Bolting DN 40		•	•	•		
Bolting DN 50		•	•	•		
Hygienic connection with compression nut F40 PN 25		•				
Hygienic connection with tension flange DN 32 PN 25		•				
Varivent		•				
Tuning fork material						
1.4581 (316)			•	•	•	•
2.4610 (Hastelloy C4)			•	•	•	•
Material, mechanical connection						
1.4571 (316 Ti)	•	•	•	•	•	•
2.4610 (Hastelloy C4)			•	•	•	•
Coating						
ECTFE (Halar)			•	•	•	•
Säkapphen			•	•	•	•
Enamel			•	•	•	•

	71A	75A	81A	83A	81A ExD	83A ExD
Oscillator						
Contactless electronic switch (C)	•	•	•	•	•	•
Relay output (R) DPDT			•	•	•	•
Transistor output (T)	•	•	•	•	•	•
Two-wire output 8 mA/16 mA (B)			•	•	•	•
Temperature adapter						
1.4571 (316 Ti)			•	•	•	•
Others						
Locking G 1 $\frac{1}{2}$, A (unpressurized)				•	•	•
Locking G 1 $\frac{1}{2}$, A up to 25 bar				•	•	•

3.2 Technical data and dimensions

VEGASWING 71A/75A

Housing

Housing material	stainless steel 1.4571
Protection	IP 67
Plug connection	4-pole plug with status indication (illuminated ring)
Terminals	max. 1 x 1.5 mm ²

Process connection

VEGASWING 71A	
- thread	G 1 A or 1" NPT
- material	1.4571 (stainless steel)
VEGASWING 75A	
- thread	G 1 A or 1" NPT
- conus	DN 25
- Tri-Clamp	1 1/2" or 2"
- bolting	DN 40 or DN 50
- Tuchenhagen Varivent	
- hygienic connection with compression nut F 40 PN 25	
- hygienic connection with tension flange DN 32 PN 25	

Tuning fork

Material	1.4581 (stainless steel)
----------	--------------------------

Weight

Total weight	0.4 kg (VEGASWING 71A)
--------------	------------------------

Ambient conditions

Ambient temperature on the housing	-40°C ... +70°C
Storage and transport temperature	-40°C ... +80°C
Product temperature	-40°C ... +150°C

Permissible ambient temperature

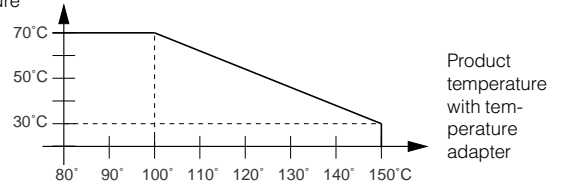

Operating pressure

Operating pressure	max. 25 bar
Test pressure	max. 40 bar

Product

Viscosity	0.2 ... 10.000 mPa s
Density	≥ 0.6 g/cm ³

Electronics (transistor output SWINGE72T)

Supply voltage	10 ... 55 V DC
Power consumption	max. 0.5 W
Output	floating transistor output NPN/PNP selectable
Load current	max. 400 mA (output - overload and permanently shortcircuit resistant)
Voltage loss	max. 1 V
Turn-on voltage	max. 55 V DC
Blocking current	< 10 µA
Protection class	II
Overvoltage category	III

Electronics (contactless electronic switch SWING E72C)

Supply voltage	20 ... 250 V AC, 50/60 Hz or 20 ... 250 V DC
Output	contactless electronic switch
Internal current requirement	approx. 3 mA (via load circuit)
Load current	min. 10 mA max. 400 mA (at I > 300 mA the ambient temperature can be max. 60°C)
Protection class	I
Overvoltage category	III
Modes	A/B mode by electrical connection in the connection plug A - max. detection, overflow protection B - min. detection, dry run protection of pumps

Function

Modes	A/B mode by polarisation of the supply voltage A - max. detection or overflow protection B - min. detection or dry run protection of pumps
Integration time	approx. 0.5 sec
Meas. frequency	approx. 400 Hz
Hysteresis	approx. 4 mm with perpendicular installation
Signal lamp	illuminated ring with two-colour LED (green - output conducts, red - output blocks) for indication of the switching condition (only in conjunction with plug connection)

CE conformity 

VEGASWING 71A and 75A vibrating level switches meet the protective regulations of EMC (89/336/EWG) and NSR (73/23/EWG). Conformity has been judged by means of a typical configuration by means of the following standards:

EMC	Emission	EN 50 081 - 1: 1992
	Susceptibility	EN 50 082 - 2: 1995
NSR		EN 61 010 - 1: 1993

VEGASWING 81A and 83A**Housing**

Housing material	PBT (Polyester)
Protection	IP 66
Cable entry	1 x M20 x 1.5 (E82 R: 2 x M20 x 1.5)
Terminals	max. 1 x 1.5 mm ²

Mechanical connection

Thread	G 1 A or 1" NPT
- material	1.4571 (stainless steel) or Hastelloy C4 (2.4610)
Flanges	DIN and ANSI from DN 50 see table "3.5 Flanges"
- material	1.4571, 1.4571 with Hastelloy C4 plating DN 50 PN 40 enamelled steel
Hygienic fittings	
- material	1.4571
- conus	DN 25
- bolting	DN 40, DN 50
- Tri-Clamp	1 1/2", 2"

Tuning fork

Material	1.4581 (stainless steel), Hastelloy C4, Hastelloy C4 enamelled, 1.4581 with Säkaphen or ECTFE coated
----------	--

Extension tube (VEGASWING 83A)

Material	1.4571 (stainless steel), Hastelloy C4, Hastelloy C4 enamelled, 1.4571 with Säkaphen or ECTFE coated
Length	
- steel 1.4571, Hastelloy C4	200 mm ... 4 m
- Hastelloy C4 enamelled	200 mm... 1200 mm

Weight

Plastic housing	approx. 1.5 kg
Stainless steel housing	approx. 2.0 kg
Tube extension (VEGASWING 83)	approx. 0.11 kg/m

Ambient conditions

Ambient temperature on the housing	-40°C ... +70°C
Storage and transport temperature	-40°C ... +70°C
Product temperature	-40°C ... +100°C briefly (30 mins.) up to 150°C (only for instruments without approval)
Product temperature with temperature adapter of 1.4571 (option)	-40°C ... +150°C

Permissible ambient temperature

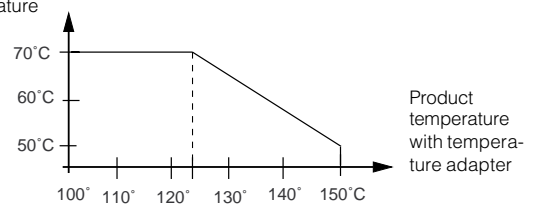

Operating pressure

Operating pressure	max. 25 bar
Test pressure	max. 40 bar

Product

Viscosity	0.2 ... 10.000 mPa s (with density 1)
- dynamic	0.7 ... 2.5 g/cm ³
Density	(0.5 ... 0.7 g/cm ³ by readjusting)

Function

Modes	A/B mode in oscillator or definition via the signal conditioning instrument (SWING E82B) A - max. detection or overflow protection B - min. detection or dry run protection
Integration time	approx. 500 ms
Meas. frequency	approx. 380 Hz
Hysteresis	approx. 4 mm with perpendicular installation
Signal lamp	LED for indication of the switching condition LED lights when tuning fork is covered
- SWING E80C, R, T	
- SWING E80 Z, E80 Z Ex	

Locking up to 25 bar or unpressurised

Tube diameter of the sensor	Ø 29 mm (DIN 2463/2462 D4-T3)
Material	1.4571 or 1.4435
Product temperature	-50°C ... +150°C
Operating pressure	
- ARV	unpressurised
- ARV2...B	25 bar

CE conformity

VEGASWING 81A and 83A vibrating level switches meet the protective regulations of EMC (89/336/EWG) and NSR (73/23/EWG). Conformity has been judged acc. to the following standards:

EMC	Emission	EN 50 081 - 1: 1992
	Susceptibility	EN 50 082 - 2: 1995
NSR		EN 61 010 - 1: 1993

VEGASWING 81A EXD and 83A EXD**Housing**

Housing material	Aluminium (plastic coated)
Protection	IP 66 and IP 67 (meets both protections)
Cable entry	1/2" NPT EExd
Terminals	max. 1 x 1.5 mm ² wire cross-section

Mechanical connection

Thread	G 1 A or 1" NPT
- material	1.4571 (stainless steel) or 2.4610 (Hastelloy C4)
Flanges	DIN and ANSI ab DN 50
- material	1.4571, 1.4571 with Hastelloy C4 plating DN 50 PN 40 enamelled steel or 1.4571 ECTFE coated
Hygienic fittings	
Material	1.4571 (stainless steel)
- conus	DN 25
- bolting	DN 40, DN 50
- TRI-Clamp	1 1/2", 2"
- Tuchenhagen Varivent	DN 50 PN 10
- hygienic connection with compr. nut	F40 PN 25, 14571, 14581
- hygienic connection with tension flange	DN 32 PN 25, 1.4571, 1.4581

Tuning fork

Material	1.4581, Hastelloy C4, Hastelloy C4 enamelled 1.4581, with ECTFE coating
----------	--

Extension tube (VEGASWING 83A EXD)

Material	1.4571, Hastelloy C4, Hastelloy C4 enamelled 1.4571 with ECTFE coating
Length	
- 1.4571, Hastelloy C4	180 mm ... 4000 mm
- Hastelloy C4 enamelled	180 mm ... 1200 mm
- 1.4571, ECTFE (Halar)	180 mm ... 3000 mm

Weight

Basic weight	approx. 2.5 kg
Tube extension	approx. 0.11 kg/m

Ambient conditions ¹⁾

Ambient temperature on the housing	-40°C ... +70°C
Storage and transport temperature	-40°C ... +70°C
Product temperature	-40°C ... +100°C
Product temperature with temperature adapter of 1.4571 (option)	-40°C ... +150°C

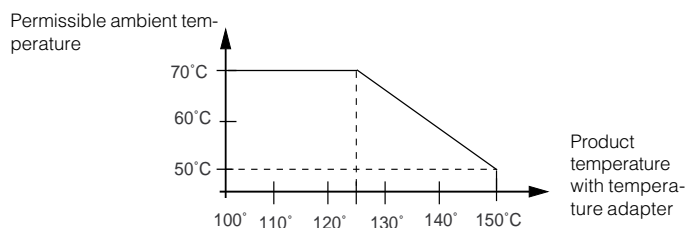
**Operating pressure ¹⁾**

Operating pressure	-1 bar ... 40 bar (with locking ARV2EX0.C... up to 25 bar, other locking unpressurised). For flange versions not the nominal pressure of the flange.
--------------------	--

Product

Viscosity	
- dynamic	0.2 ... 10.000 mPa s (or cP)
- kinematic	0.2 ... 10.000 mm ² /s (or cSt) relating to density 1.0 g/cm ³
Density	0.5 ... 2.5 g/cm ³ 0.5 ... 0.7 g/cm ³ must be re-adjusted (factory setting 1.0)

¹⁾ Note the information in the conformity certificate or the EC type approval.

Function

Mode	A/B mode in the oscillator or definition via the signal conditioning instrument (SWING E82 Z) A: max. detection, overflow protection B: min. detection, dry run protection of pumps
Integration time	approx. 0.5 s
Meas. frequency	approx. 400 Hz
Hysteresis	approx. 4 mm with perpendicular installation

CE conformity 

VEGASWING 81A EXD and 83A EXD vibrating level switches meet the protective regulations of EMC (89/336/EWG) and NSR (73/23/EWG). Conformity has been judged acc. to the following standards:

EMC	Emission	EN 50 081 -1: 1992
	Susceptibility	EN 50 082 -2: 1995
NSR		EN 61 010 -1: 1993

Approvals VEGASWING 80A 

Water resources law (WHG)

Approval as overflow protection acc. to WHG	
Ambient temperature on the housing	-40°C ... +70°C
Product temperature	-40°C ... +100°C (test report PA VI 810.74 and Z-65.11-14) with temperature adapter up to 150°C
Operating pressure	max. 25 bar

Explosion protection Ex-Zone 0

Approval for the use in Zone 0 along with ElexV (Germany: Ex-Zone 0)

Classification mark	EEx ia IIC T6
Ambient temperature on the housing depending on the temperature class	
- VEGASWING 81... Z5 Ex, 83... Z5 Ex (T6)	-20°C ... +60°C
- VEGASWING 81... Z5 Ex, 83... Z5 Ex (T5)	-20°C ... +70°C
- VEGASWING 81... Z7 Ex, 83... Z7 Ex (T6)	-20°C ... +70°C
Product temperature (statement: only if there is no Ex atmosphere, Zone 0: -20°C ... +60°C)	
- temperature class T6	-20°C ... +85°C
- temperature class T5	-20°C ... +100°C
- temperature class T4	-20°C ... +135°C (from 100°C only with temperature adapter)
Operating pressure	max. 4 bar (-20 ... +60°C: if zone 0 is requirement) > 4 bar, if there is no Ex atmosphere
Only for connection to certified intrinsically safe operating facilities with the following max. values:	
- voltage U_o	23.1 V
- current I_k	126 mA
Internal capacitance C_i	~ 0 µF
Internal inductance L_i	~ 0 H

Explosion protection acc. to the CENELEC Ex regulations

Approval acc. to the Ex regulations	
Classification mark	EEx ia IIC T6
Ambient temperature on the housing depending on the temperature class	
- VEGASWING 81... Z5 Ex, 83... Z5 Ex (T6)	-20°C ... +60°C
- VEGASWING 81... Z5 Ex, 83... Z5 Ex (T5)	-20°C ... +70°C
- VEGASWING 81... Z7 Ex, 83... Z7 Ex (T6)	-20°C ... +70°C
Product temperature	
- temperature class T6	-20°C ... +85°C
- temperature class T5	-20°C ... +100°C
- temperature class T4	-20°C ... +135°C (from 100°C only with temperature adapter)

Approvals VEGASWING 80A EXD

Water resources law (WHG)

Approval as overflow protection acc. to WHG applied for

Recurring test acc. to WHG

According to the type approval acc. to WHG (Z-65.11-154 applied for) the recurring test acc. to WHG can be carried out by pushing the test key on the VEGATOR 536 EX, 537 EX, 636 EX signal conditioning instrument. The sensor must neither be removed nor response triggered by filling the vessel. This is valid for VEGASWING 81A EXD and 83A EXD with two-wire oscillator SWING E82 Z EX.

Explosion protection VEGASWING 81A EXD, 83A EXD

Certificate	EC type approval certificate acc. to ATEX 100 a
Classification mark	ATEX II 2G EEx d IIC T6
Permissible application range	Ex Zone 1
Ambient temperature depending on temperature class and Ex zone:	see EC type approval certificate
Electrical safety-relevant characteristics:	see EC type approval certificate

Oscillators

C - Contactless electronic switch (SWING E82C)

Supply voltage	20 ... 250 V AC, 50/60 Hz or 20 ... 250 V DC
Output	contactless electronic switch
Internal current consumption	approx. 3 mA (via the load circuit)
Load current	min. 10 mA max. 400 mA (at I > 300 mA the ambient temperature can be max. 60°C)
	max. 4 A up to 40 ms (not WHG specified)
Protection class	I
Overvoltage category	III
Modes (switchable)	A = max. detection or overflow protection B = min. detection or dry run protection

R - Relay output (SWING E82R)

Supply voltage	20 ... 250 V AC, 50/60 Hz or 20 ... 72 V DC (at U > 60 V the ambient temperature can be max. 50°C)
Power consumption	1 ... 8 VA (AC), approx. 1 W (DC)
Output	relay output (DPDT) 1 floating spdt
Contact material	AgCdO and Au plated
Turn-on voltage	min. 10 mV max. 250 V AC, 250 V DC
Switching current	min. 10 µA max. 5 A AC, 1 A DC
Breaking capacitance	max. 750 VA AC, 54 W DC
Protection class	I
Overvoltage category	II
Modes	A = max. detection or overflow protection/ overflow protection B = min. detection or dry run protection of pumps

T - Transistor output (SWING E82T)

Supply voltage	10 ... 55 V DC
Power consumption	max. 0.5 W
Output	floating transistor output overload and permanently short circuit resistant
Load current	max. 400 mA
Voltage loss	max. 1 V
Turn-on voltage	max. 55 V DC
Blocking current	< 10 µA
Protection class	II
Overvoltage category	III
Modes	A = max. detection or overflow protection/ overflow protection B = min. detection or dry run protection

B - Two-wire output (SWING E82B)

Supply voltage	12 ... 36 V DC (via the VEGA signal conditioning instrument)
Output	two-wire output
Required signal conditioning instrument	VEGATOR 534 Ex, 536 Ex, 537 Ex, 636 Ex, VEGALOG 571
Current consumption:	
- tuning fork uncovered	approx. 8 mA
- tuning fork covered	approx. 16 mA
- fault signal	> 22 mA
Protection class	II
Overvoltage category	III
Modes	definition via the signal conditioning instrument

Ex version with integrated SWING E82B Ex

Voltage	12 ... 23 V of VEGA ... Ex instruments
Required signal conditioning instrument	VEGATOR 534 Ex, 536 Ex, 537 Ex, 636 Ex other signal conditioning instruments with safety barrier 145
Classification mark	EEx ia IIC T6
Safety barrier type 145 can be used for connection of SWING E82B Ex to non-Ex signal conditioning instruments.	

VEGASWING 71 A

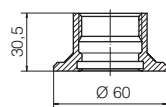
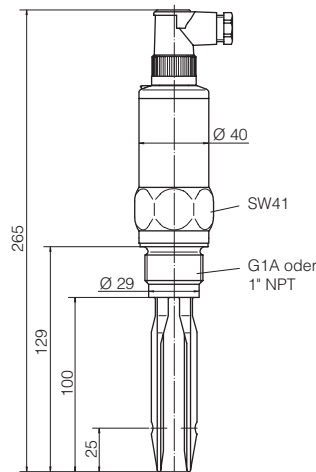

Optional with weld mark

Front side
O-ring seal

VEGASWING 75 A

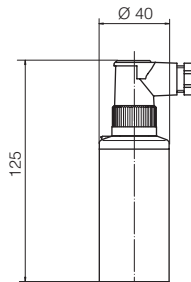

Housing IP 66/IP 67 of 1.4571 with plug

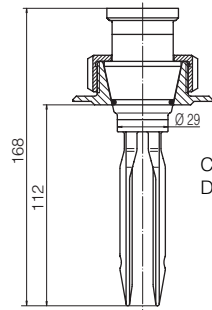

Conus
DN 25

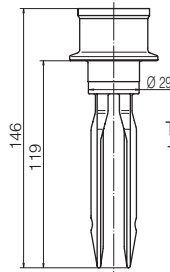

TRI-Clamp
1 1/2"

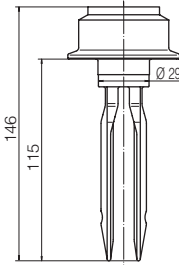

TRI-Clamp 2"

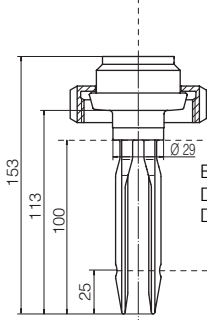

Bolting
DN 40 / 50
DIN 11 851

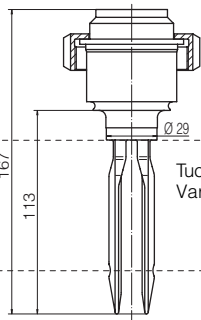

Tuchenhagen
Varivent

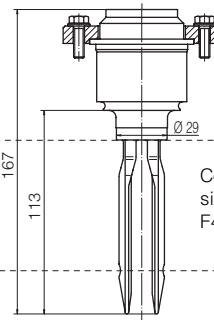

Compression nut
F40 PN 25

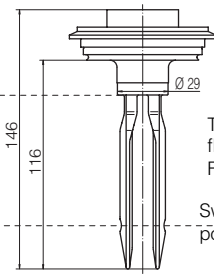

Tension flange
F32 PN 25
Switching point

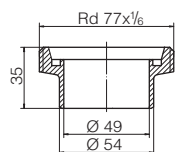
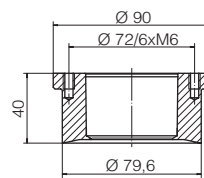
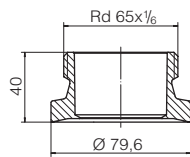
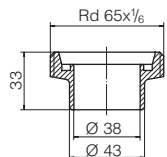

VEGASWING 81A

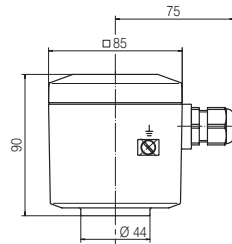

Temperature adapter of 1.4571 (option)



Thread
G 1 A or 1" NPT

Conus DN 25

TRI-Clamp 1 1/2"

TRI-Clamp 2"

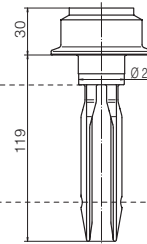
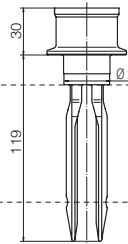
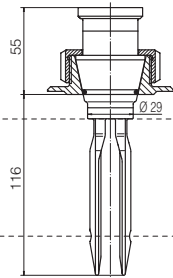
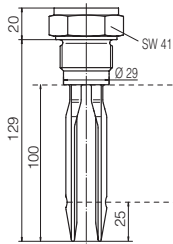

Switching point

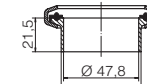
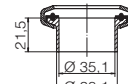
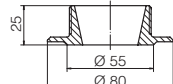
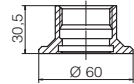

Bolting
DN 40/50, DIN 11 851

Compression nut
F40 PN 25

Tension flange
F32 PN 25

Tuchenhagen
Varivent

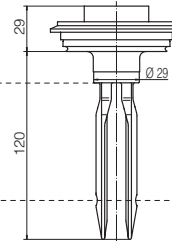
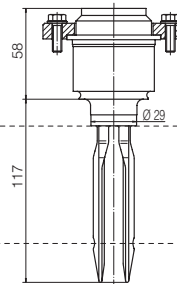
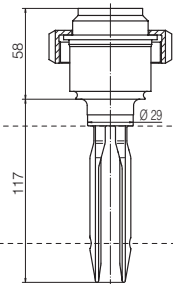
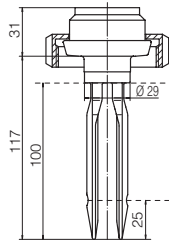

Switching point

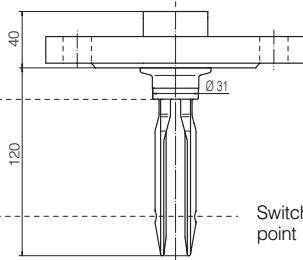
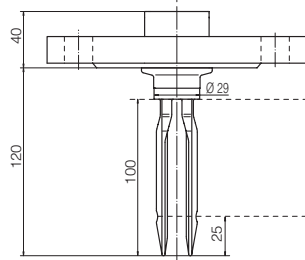
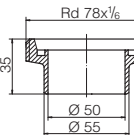
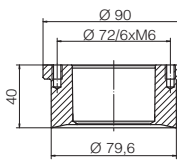
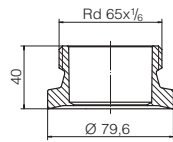
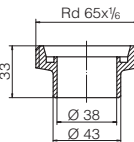

Switching point

VEGASWING 83A

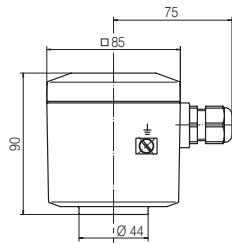

Temperature adapter of 1.4571 (option)

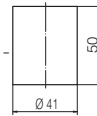

Thread G 1 A or 1" NPT

Conus DN 25

TRI-Clamp 1 1/2"

TRI-Clamp 2"

Bolting DN 40/50, DIN 11 851

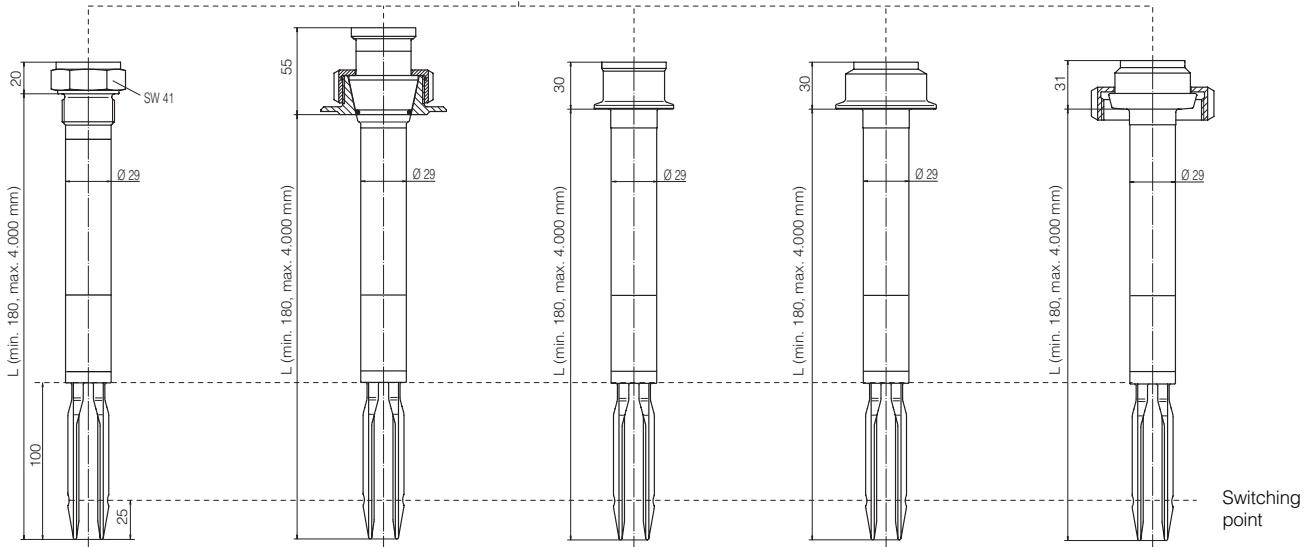

Switching point

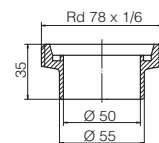
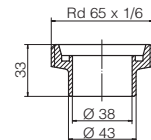
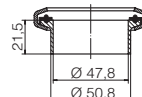
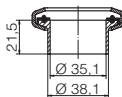
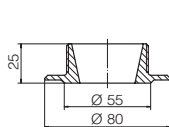
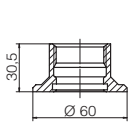

VEGASWING 83A

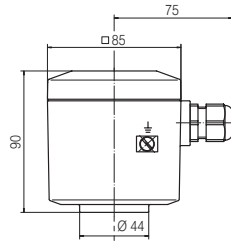

Temperature adapter of 1.4571 (option)

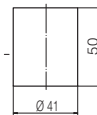

Compression nut F40 PN 25

Tension flange F32 PN 25

Tuchenhagen Varivent

Flange DN 50

enamelled

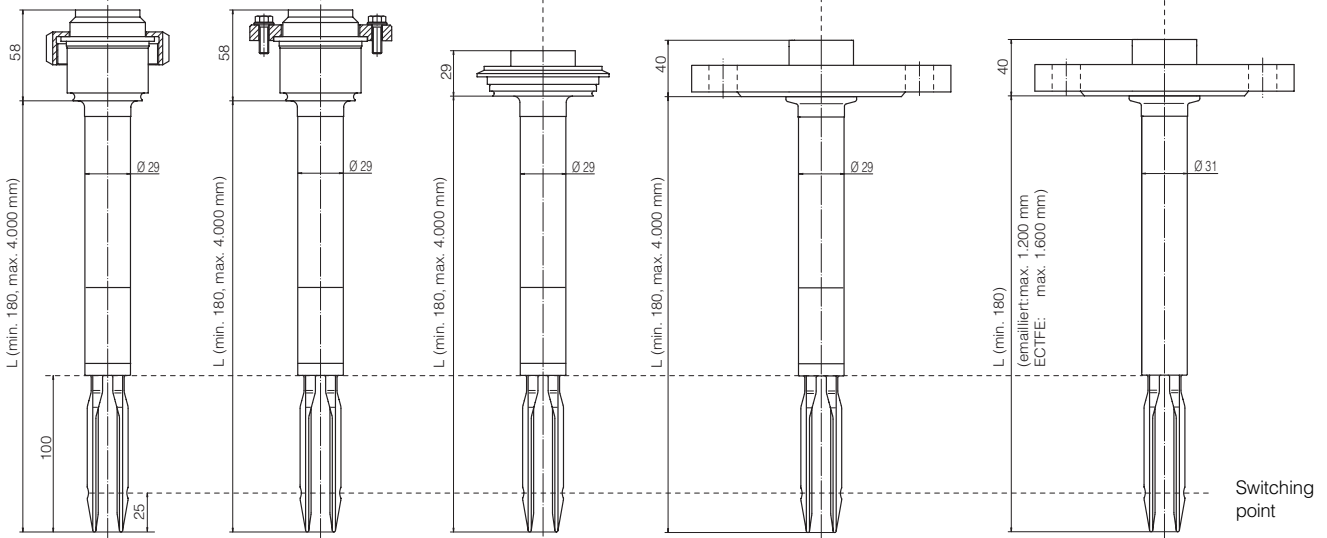

Locking up to 25 bar

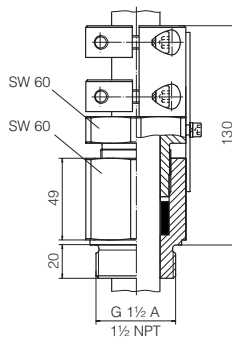
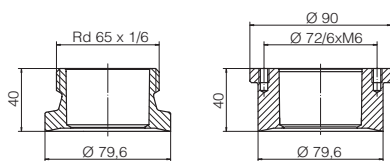

Locking for height adjustment (accessory)

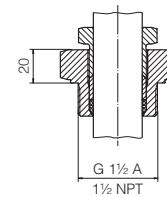

VEGASWING 81A ExD

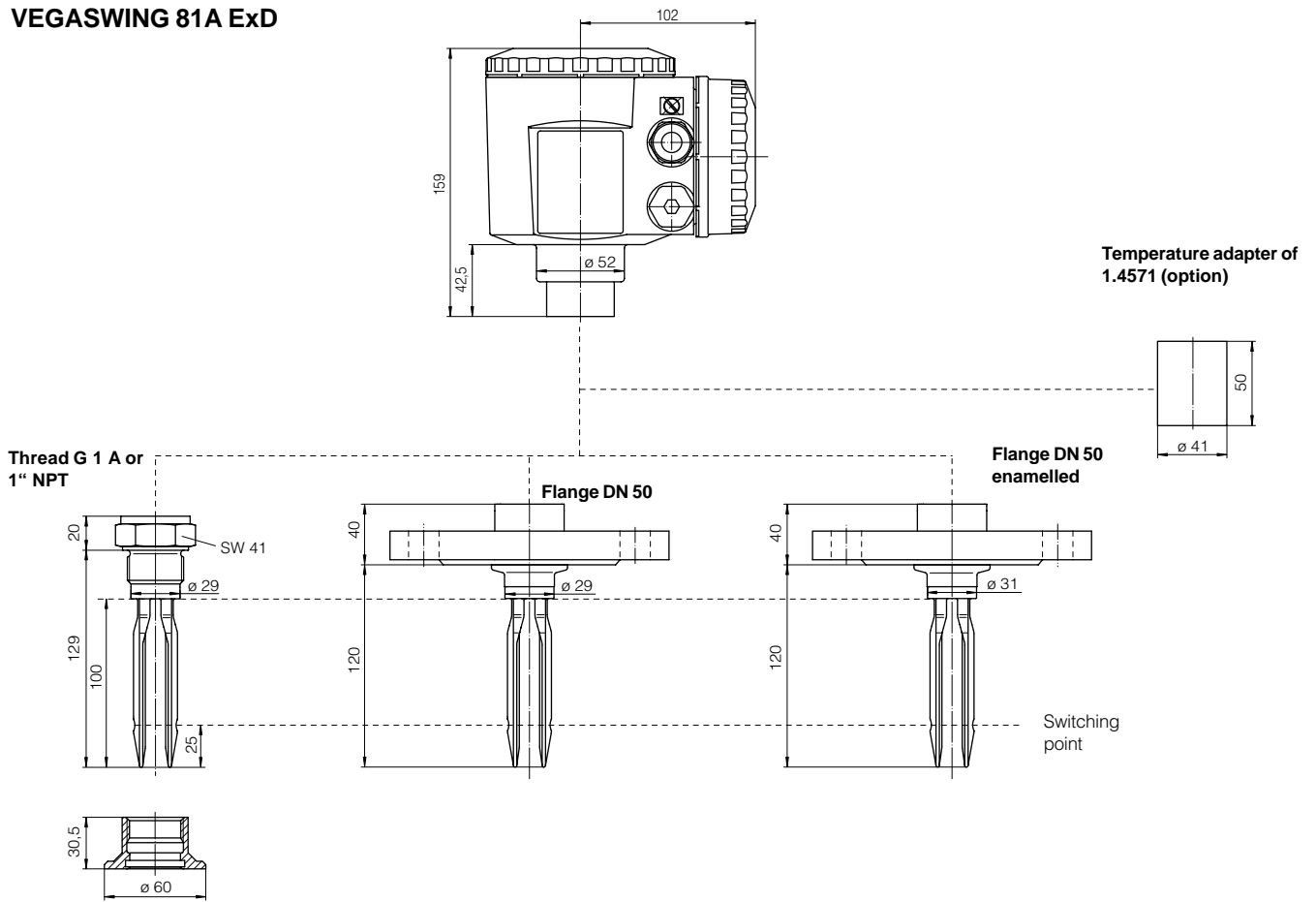

VEGASWING 83A ExD

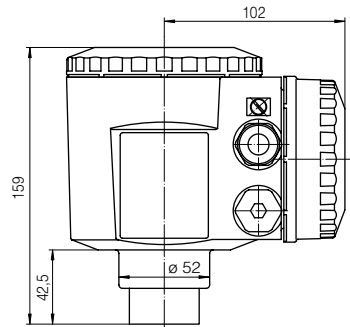

Temperature adapter of 1.4571 (option)

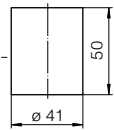

Thread G 1 A or 1" NPT

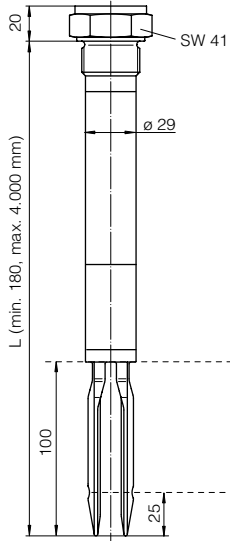

Flange DN 50

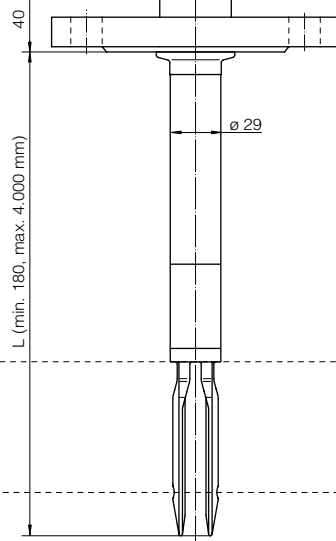

Flange DN 50 enamelled

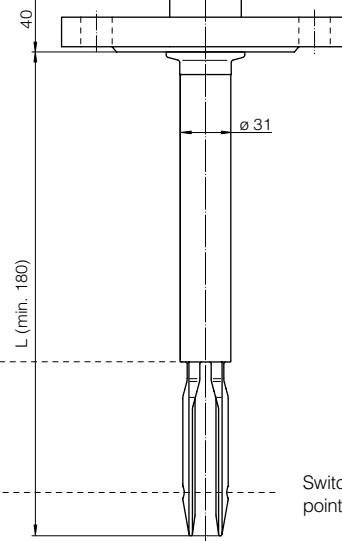

Switching point

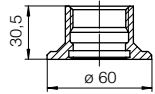

3.3 Technical data signal conditioning instruments and dimensions

VEGATOR 536 Ex, 537 Ex

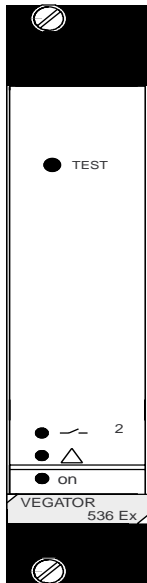

General

Series	module unit for carrier 596 Ex
Dimensions	W = 25.4 mm (5 TE), H = 128.4 mm, D = 162 mm
Weight	approx. 180 g

Ambient conditions

Ambient temperature	-20°C ... +60°C
Storage and transport temperature	-40°C ... +70°C

Power supply

Operating voltage	20 ... 53 V AC, 20 ... 72 V DC
Power consumption	max. 3 W
Electrical connection	multiple plug DIN 41 612, series F (d, b, z) 33-pole

Electrical protective measures

Protection class	II
Overvoltage category	II
Protection	
- mounted into housing type 505 Ex	IP 30
Protection (mounted into carrier type 596 Ex with Ex module)	
- front side (completely assembled)	IP 30
- upper and lower side	IP 20
- wiring side	IP 00

Inputs

Number of inputs	
- VEGATOR 536 Ex	1 sensor input
- VEGATOR 537 Ex	2 sensor inputs
Data transmission	analogue
Switching threshold	12 mA
Current limitation	24 mA (permanently short circuit resistant)
Sensor supply voltage	approx. 15 ... 18 V DC
Connection cable	2-wire
Resistance per wire	max. 35 Ω
Integration time	0.1 ... 20 s, directional switching (adjustment via DIL switch)

Relay output

Number, function	
- VEGATOR 536 Ex	1 switching relay (spdt), 1 fail safe relay
- VEGATOR 537 Ex	2 switching relays (spdt), 1 fail safe relay
Modes	A/B-mode
	A - max. detection or overfill protection
	B - min. detection or dry run protection of pumps
Contact	1 spdt each
Contact material	AgCdO and Au-plated
Turn-on voltage	min. 10 mV
	max. 250 V AC, 250 V DC
Switching current	min. 10 μA
	max. 3 A AC, 1 A DC
Breaking capacitance	max. 500 VA AC, 54 W DC

Transistor output

Number, function	
- VEGATOR 536 Ex	2, synchronous switching with the relays
- VEGATOR 537 Ex	3, synchronous switching with the relays
Galvanic separation	floating
Max. values	U_B max. = 36 V DC
	I_B max. = 60 mA
Transistor voltage loss	U_{CE} min. - 1.5 V at $I_B = 60$ mA
Blocking current	< 10 μA

Approvals



Classification intrinsic safety EEx ia IIC or EEx ia IIB
 Max. values $U_0 = 20\text{ V}$
 $I_K = 126\text{ mA}$
 $P = 627\text{ mW}$
 Characteristics linear

	EEx ia IIC			EEx ia IIB	
	0.5	1.0	1.5	< 0.5	0.5 ... 20
Max. permissible outer inductance (mH)	0.5	1.0	1.5	< 0.5	0.5 ... 20
Max. permissible outer capacitance (nF)	97	78	68	97	486

The intrinsically safe circuits are reliably galvanically separated from all non-intrinsically safe circuits up to a peak value of the nominal voltage of 375 V.
 The intrinsically safe circuits of channels 1 and 2 are reliably separated.

Electrical connection

Mounted into
 - carrier BGT 596 Ex 33-pole multiple plug, series F d, b, z with coding holes
 - housing type 505 Ex screw terminals, max. for 1.5 mm²

CE conformity

The signal conditioning instrument meets the protective regulations of EMC (89/336 EWG) and NSR (73/23/EWG).

Conformity has been judged acc. to the following standards:

EMC	Emission	EN 50 081 - 1: 1993
	Susceptibility	EN 50 082 - 2: 1995
NSR		EN 61 010 - 1: 1993

Indicating elements

LED in the front plate
 - green on operating voltage on
 - yellow switching point control
 - red fault signal

Series 500

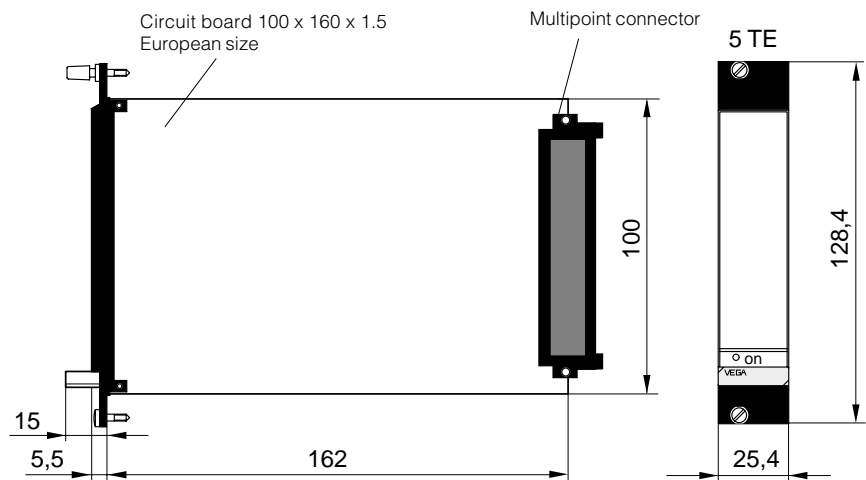

VEGATOR 636 Ex

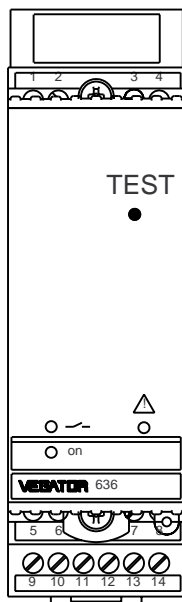

General

Series	module unit with plug-in socket for carrier rail mounting acc. to DIN 46 277, Bl. 3
Dimensions	W = 36 mm (5 TE), H = 118.5 mm, D = 134 mm
Weight	approx. 170 g

Ambient conditions

Ambient temperature	-20°C ... +60°C at an operating voltage of 60 ... 72 V DC the permissible ambient temperature reduces linear from 60°C to 40°C
Storage and transport temperature	-40°C ... +70°C

Power supply

Operating voltage	20 ... 250 V AC, 50/60 Hz 20 ... 72 V DC
Power consumption	max. 3 W (3 ... 18 VA)

Electrical protective measures

Protection class	II
Overvoltage category	II
Protection	
- instrument	IP 30
- plug-in socket	IP 20
Electrical separating measures	reliable separation (VDE 0106, part 1) between power supply, meas. data input, level relay and transistor output

Inputs

Number of inputs	1 current input
Data transmission	analogue
Sensor supply voltage	approx. 15 ... 18 V DC
Hysteresis	100 µA fix
Switching threshold	12 mA
Current limitation	24 mA, permanently short circuit proof
Connection cable	2-wire
Resistance per wire	max. 35 Ω
Integration time	0.1 ... 20 s, directional switching

Relay output

Number, function	1 switching relay (spdt)
Modes	A/B-mode A - max. detection or overflow protection B - min. detection or dry run protection of pumps
Contact	1 spdt each
Contact material	AgCdO and Au-plated
Turn-on voltage	min. 10 mV DC max. 250 V AC, 250 V DC
Switching current	min. 10 µA DC max. 3 A AC, 1 A DC
Breaking capacitance	max. 500 VA AC, 54 W DC

Transistor output

Number, function	1, synchronous switching with relays
Galvanic separation	floating
Max. values	U_B max. = 36 V DC I_B max. = 60 mA (short circuit proof)
Transistor voltage loss	U_{CE} min. - 1.5 V at I_B = 60 mA
Blocking current	< 10 µA

Indicating elements

LED in the front plate
 - green on operating voltage on
 - yellow switching point control
 - red fault signal

Approvals 

Classification intrinsic safety EEx ia IIC or EEx ia IIB
 Max. values U_0 - 20 V
 I_k - 125 mA
 P - 624 mW
 Characteristics linear

	EEx ia IIC			EEx ia IIB	
Max. permissible outer inductance (mH)	0.5	1.0	1.5	< 0.5	0.5 ... 20
Max. permissible outer capacitance (nF)	97	78	68	97	486

The intrinsically safe circuits are reliably galvanically separated from all non-intrinsically safe circuits up to a peak value of the nominal voltage of 375 V.
 The max. voltage on the non-intrinsically safe circuits must not exceed 250 V_{eff} in case of failure.

Electrical connection

Screw terminal max. for 1.5 mm²

CE conformity 

The signal conditioning instrument meets the protective regulations of EMC (89/336 EWG) and NSR (73/23/EWG).

Conformity has been judged acc. to the following standards:

EMC	Emission	EN 50 081 - 1: 1993
	Susceptibility	EN 50 082 - 2: 1995
NSR		EN 61 010 - 1: 1993

Series 600

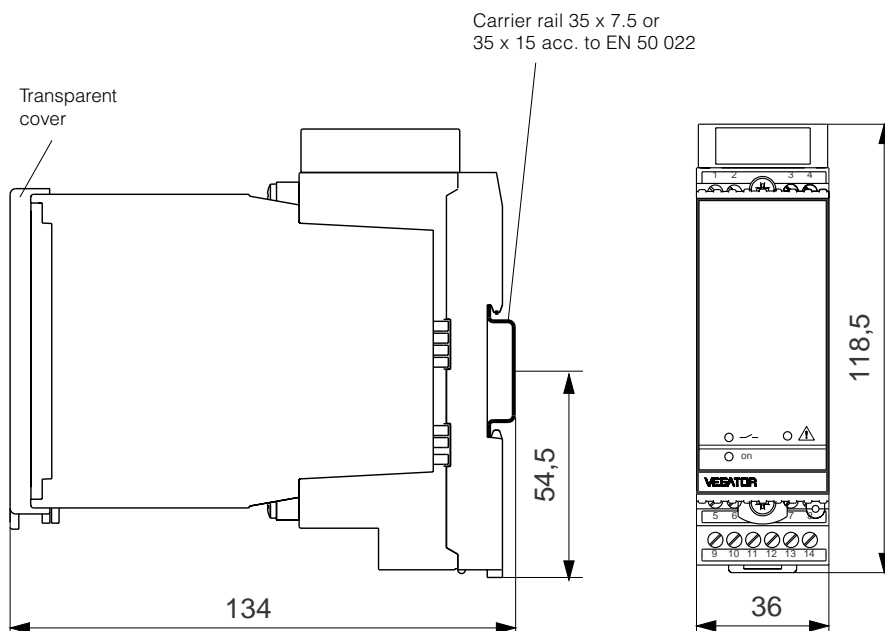

3.4 Flanges

Welded flanges

According to the DIN or ANSI standards, the welded flanges for VEGASWING 81F.../83F... are manufactured generally in stainless steel 1.4571. The dimensions of the standard flanges are listed in the following tables.

As protection against aggressive liquids the wetted parts can be provided with a plastic coating.

VEGASWING 81

Coating of flange and tuning fork with ECTFE (Halar) or enamel.

VEGASWING 83

Coating of flange, extension tube and tuning fork with Säkaphen, ECTFE (max. 1200 mm) or enamel (max. 800 mm).

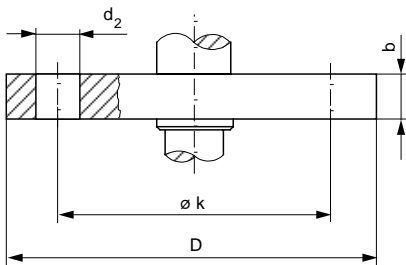

D = outer flange diameter
b = flange thickness
k = diameter of hole circle
 d_2 = diameter of holes

Flanges acc. to DIN

Flange DN	PN	Dimensions			Holes		
		D	b	k	No.	Screws	d_2
50	6	140	14	110	4	M12	14
50	40	165	20	125	4	M16	18
65	6	160	14	130	4	M12	14
65	40	185	22	145	8	M16	18
80	6	190	16	150	4	M16	18
80	40	200	24	160	8	M16	18
100	16	220	20	180	8	M16	18
150	16	285	22	240	8	M20	22

Flanges acc. to ANSI

Flange ANSI	psi	Dimensions			Holes		
		D	b	k	No.	Screws	d_2
1 1/2"	150	127.0	17.5	98.4	4	M14	15.9
1 1/2"	300	155.6	20.6	114.4	4	M20	22.2
2"	150	152.4	19.0	120.6	4	M16	19.0
2"	300	165.1	22.2	127.0	4	M16	19.0
2 1/2"	150	177.8	22.2	139.7	4	M16	19.0
2 1/2"	300	190.5	25.4	149.2	8	M20	22.2
3"	150	190.5	23.8	152.4	4	M16	19.0
3"	300	209.5	28.6	168.3	8	M20	22.2
4"	150	228.6	23.8	190.6	8	M16	19.0

Note:

The permissible pressure load of the flanges is partly below the value of VEGASWING of 25 bar.

Threaded flanges

According to the DIN or ANSI standards, the threaded flanges for VEGASWING 81F.../83F... are manufactured generally in stainless steel 1.4571 (V4A).

The dimensions of the standard flanges are listed in the following tables.

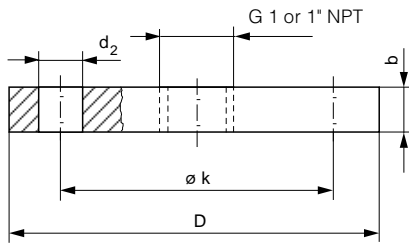

- D = outer flange diameter
- b = flange thickness
- k = diameter of hole circle
- d₂ = diameter of holes

Flanges acc. to DIN with G 1 or 1" NPT

Flange DN	PN	Dimensions			Holes		d ₂
		D	b	k	No.	Screws	
40	40	150	18	110	4	M16	18
50	40	165	20	125	4	M16	18
80	40	185	24	160	8	M16	18
100	40	200	24	190	8	M16	20

Flanges acc. to ANSI with G 1 or 1" NPT

Flange ANSI	psi	Dimensions			Holes		d ₂
		D	b	k	No.	Screws	
1 1/2"	150	127.0	17.5	98.4	4	M14	15.9
2"	150	152.4	19.0	120.6	4	M16	19.0
3"	150	190.5	23.8	152.4	4	M16	19.0
4"	150	228.6	23.8	190.6	8	M16	19.0

Note:

The permissible pressure load of the flanges is partly below the value of VEGASWING of 25 bar.

3.5 Application examples

Single point control

Measuring system for detection of the max. level, e.g. overflow protection or emptying pump.

Vibrating level switch at the appropriate switching point

- mounted at the appropriate height
- as tube version, can be mounted with locking
- with tube extension in appropriate length
- suitable signal conditioning instruments (in conjunction with oscillator B) VEGATOR 536 Ex, 537 Ex or 636 Ex

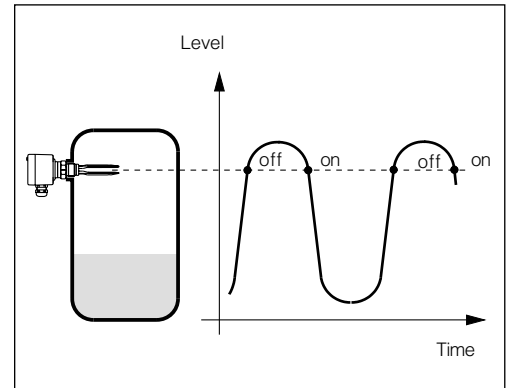

Single point control

Double point control

Measuring system for detection of two levels (alternating function) e.g. pump control

Vibrating level switch at the appropriate switching point

- mounted at the appropriate height
- as tube version, can be mounted with locking
- with tube extension in appropriate length
- suitable signal conditioning instruments (in conjunction with oscillator B) VEGATOR 537 Ex

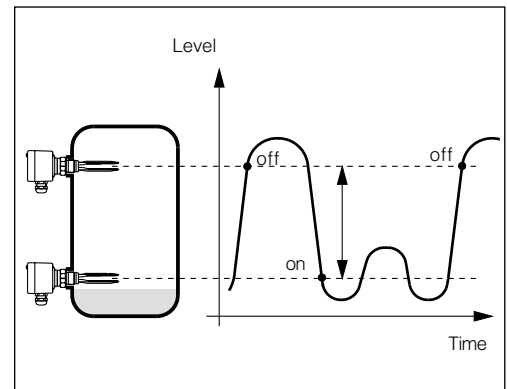

Double point control

Double single point control

Measuring system for detection of the min. and max. level

Vibrating level switch at the appropriate switching point

- mounted at the appropriate height
- as tube version, can be mounted with locking
- with tube extension in appropriate length
- suitable signal conditioning instruments (in conjunction with oscillator B) VEGATOR 534 Ex or 537 Ex

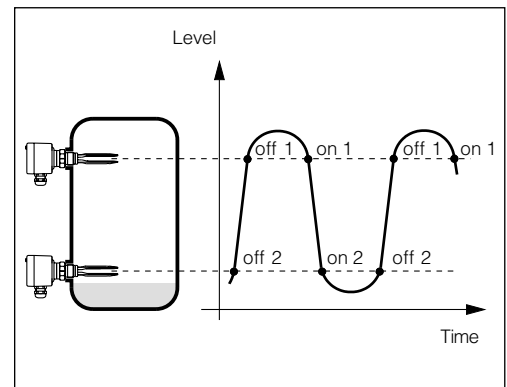

Double single point control

or

Measuring system for detection of one level each in two different vessels.

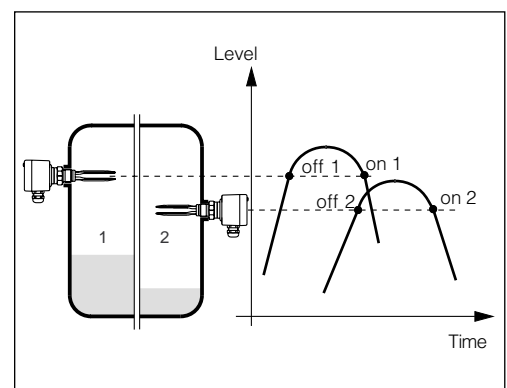

Double single point control with two vessels

Instead of VEGASWING 81A any other vibrating level switch of the VEGASWING series can be used.

3.6 Approvals

If measuring systems are installed according to the following approvals, the appropriate official documents must be noted and their regulations strictly observed. The documents are supplied with the respective measuring system.

Overfill protection according to Water Resources Law (WHG)

Level detection with fault monitoring

Instrument	Oscillator	Required signal cond.instr.VEGATOR	Certificate no. VEGATOR
Vibration VEGASWING 71 A	E72T	compact instrument	Z-65.11-141
Vibration VEGASWING 75 A	E72T	compact instrument	Z-65.11-141
Vibration VEGASWING 81B Ex, 83B Ex	E80B Ex	534 Ex 536, 536 Ex 537, 537 Ex 636 Ex	Z-65.11-23
Vibration VEGASWING 81..., 83...C,R,T	E80C E80R E80T	compact instrument	Z-65.11-14
Vibration VEGASWING fail safe ¹⁾ 81... W5 EX.C 83... W5 EX.C	E86 Ex	526 Ex	Z-65.11-31

Level measuring instruments for use in hazardous areas PTB Zone 0

(Germany)

Level detection with fault monitoring

Instrument	Conformity certificate PTB no.	Oscillator	Conformity certificate PTB no.	Required signal cond. instrument VEGATOR	Conformity certificate PTB no.
Vibration VEGASWING 81... Ex, 83... Ex	Ex-92.C.2181	E80B Ex	Ex-92.C.2181	534 Ex	Ex-93.C.4066 X
				536 Ex	Ex-95.D.2065
				537 Ex	Ex-95.D.2073 X
				636 Ex	Ex-96.D.2068

Level measuring instruments acc. to CENELEC for use in hazardous areas

Level detection with fault monitoring

Instrument	Conformity certificate PTB no.	Oscillator	Conformity certificate PTB no.	Required signal conditioning instr. VEGATOR	Conformity certificate PTB no.
Vibration VEGASWING 81... Ex, 83... Ex	Ex-92.C.2141	E80B Ex	Ex-92.C.2141	534 Ex	Ex-93.C.4066 X
				536 Ex	Ex-95.D.2065 X
				537 Ex	Ex-95.D.2073 X
				636 Ex	Ex-96.D.2068

¹⁾ Due to the proven fail-safe reaction, VEGASWING 8... W5 EX.C with VEGATOR 526 EX signal conditioning instrument is not subjected to the recurring test acc. to WHG.

4 Electrical connection

4.1 VEGASWING 71A/75A

Danger

Switch off the power supply during connection.

Floating transistor output SWING E72T

Voltage supply:
10 ... 55 V DC

(for further information see following switching examples as well technical data)

To determine the switching condition of the transistor output (mode A/B) the supply lines (terminal 1 and 4) must be polarised appropriately.

Mode A

Max. detection of overflow protection

- terminal 1: +
- terminal 4: -

Mode B

Min. detection or dry run protection of pumps

- terminal 1: -
- terminal 4: +

By different connection of the consumer (load) NPN or PNP action can be reached. In connecting, make sure that terminal 2 always has a higher positive voltage potential than terminal 3.

Switching examples

The transistor switches the supply voltage of the oscillator to the binary input of a PLC or to an electrical load.

Mode A

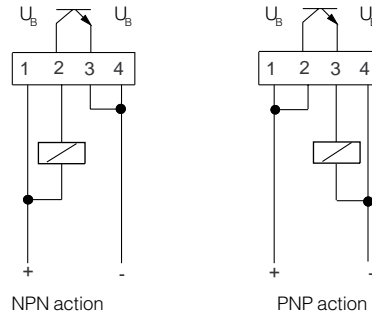

Mode B

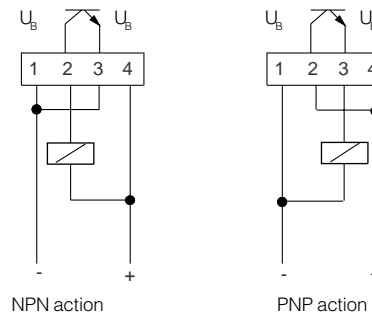

The transistor switches a second voltage source with the same reference potential to the binary input of a PLC or to an electrical load.

Mode A

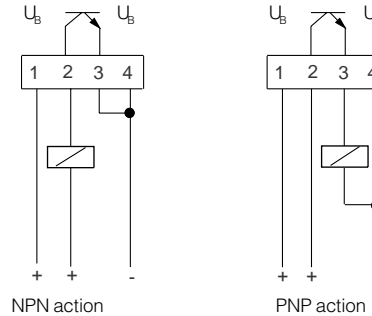

Mode B

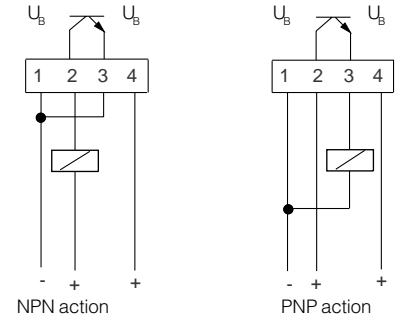

The transistor switches a second, galvanically separated voltage source to the binary input of a PLC or to an electrical load.

Mode A

For mode B the polarisation of terminals 1 and 4 must be exchanged.

NPN action

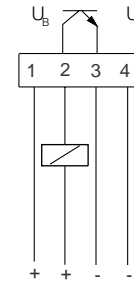

PNP action

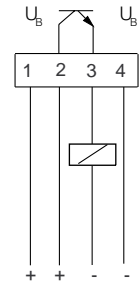

Control of alternating current loads

The transistor switches a galvanically separated alternating voltage 10 ... 42 V AC to a load.

Mode A

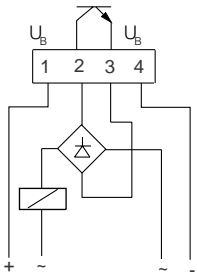

Note

The transistor outputs of several VEGASWING 71 A or 75 A can be switched in series or in parallel to connect their signals logically. The switching must be made such that terminal 2 has always higher voltage than terminal 3.

4.2 VEGASWING 80A

Danger

Switch off the power supply before starting connection work.

The electrical connection must be carried out in compliance with the integrated oscillator. Connect mains voltage according to the following wiring diagrams.

Note

If strong electromagnetic interference is expected, we recommend the use of shielded cable for the Z electronics. The shielding of the cable should be earthed on the sensor side (VEGASWING) via terminal 3.

As a rule, connect VEGASWING to vessel ground (PA) or in plastic vessels to the next ground potential. A thread (screw M4x5) is located laterally on the hexagon of the mounting boss. This connection is used to drain off electrostatic charges.



For Ex applications, the installation regulations for hazardous areas must be observed.

Contactless electronic switch (SWING E82C)

Power supply:
 20 ... 250 V AC, 50/60 Hz
 20 ... 250 V DC
 (for further information see technical data)

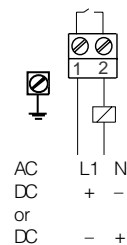

For direct control of relays, contactors, magnet valves, signal lamps, horns, etc. Must not be operated without connected load (switching in series) as otherwise the oscillator will be destroyed. Not for connection to low voltage PLC inputs.

After switching off the load, the internal current is briefly lowered below 1 mA so that contactors, the hold current of which is lower than the permanently flowing internal current, can be switched off reliably.

If VEGASWING is used as part of an overfill protection system acc. to WHG, please note the regulations of the general type approval Z-65.11-14.

Floating relay output (SWING E82R)

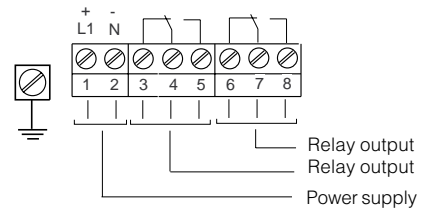

Power supply:
 20 ... 250 V AC, 50/60 Hz
 20 ... 60 V DC
 (for further information see technical data)

Used for switching external voltage sources to relays, contactors, magnet valves, signal lamps, horns, etc.

If VEGASWING is used as part of an overfill protection system acc. to WHG, please note the regulations of the general type approval Z-65.11-14.

Two-wire output (SWING E82B)

For connection to a VEGATOR signal conditioning instrument, also Ex, VbF, WHG (for plastic and stainless steel housing)

Power supply via the connected VEGATOR signal conditioning instrument (12 ... 36 V DC) (for further information see technical data)

Switching example is valid for all suitable signal conditioning instruments and the stainless steel housing. The terminal assignment with stainless steel housing corresponds to that of the plastic housing.

The signal lamp in the housing lights generally when the tuning fork is immersed, independent of the mode adjusted in the signal conditioning instrument.

Note the operating instructions of the signal conditioning instrument. Suitable signal conditioning instruments are listed under technical data.

If the VEGASWING is used in Ex area or as part of an overfill protection system acc. to WHG, the regulations of the conformity certificates PTB no. Ex-92.C.2141 or Ex-92.C.2181 or the type approval 01/PTB no. III B/S 2175 F or the test report PA-VI 810.74 must be noted.
If VEGASWING with oscillator SWING E80B Ex should be operated directly on the analogue input of a PLC, the ia-safety barrier type 145 must be connected (PTB no. Ex-95.B.2038).

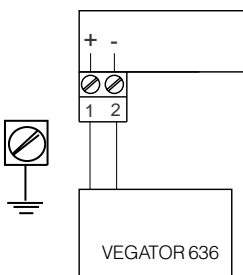

Floating transistor output (SWING E82T)

Power supply: 10 ... 55 V DC

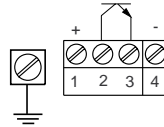

(for further information see the following switching examples as well as the technical data)

For control of relay, contactors, magnet valves, signal lamps, horns as well as PLC inputs. The shown switching examples are valid for the plastic housing. The terminal assignment of the stainless steel housing corresponds to that of the plastic housing. However, the stainless steel housing is equipped with a separate screw terminal for connection of protection earth; function earth is deleted.

Switching examples

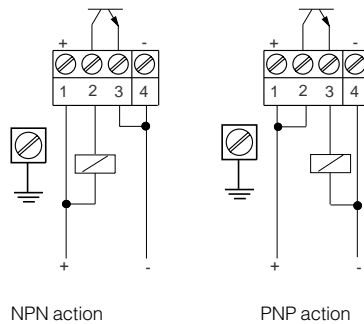

The transistor switches the supply voltage of the oscillator to the binary input of a PLC or to an electrical load. Through appropriate connection of the consumer (load), PNP or NPN action can be reached.

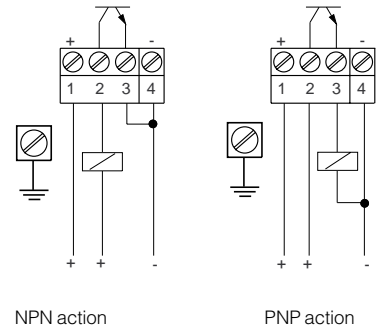

The transistor switches a second voltage source with the same reference potential to the binary input of a PLC or to an electrical load. Through appropriate connection of the consumer (load), PNP or NPN action can be reached.

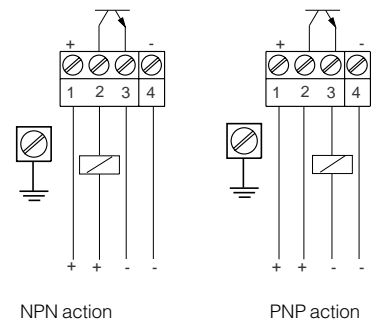

The transistor switches a second, galvanically isolated voltage source to the binary input of a PLC or an electrical load. Due to different connection of the consumer (load), PNP or NPN action can be reached.

Control of alternating current loads

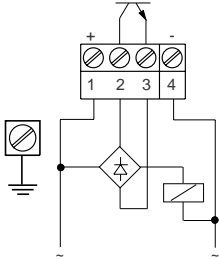

The transistor switches an alternating voltage 10 ... 42 V AC, which is also supply voltage, to a load.

Note

The transistor outputs of several VEGASWING can be switched in series or in parallel to connect their signal logically. The switching must be carried such that terminal 2 has always higher voltage than terminal 3.

4.3 Signal conditioning instruments series 500 and series 600

If only one channel should be used on a VEGATOR signal conditioning instrument, connect a resistor of 1 kΩ (0.5 W) to the unused connection pin of the second channel. The resistor prevents the output of a fault signal triggered by a missing sensor.

A transistor output operating in parallel is available to each relay output.

Reset of alarm functions

You can use the fail safe relay of VEGATOR 536 as second level relay for a signal lamp (horn etc.). An additional key switch opener can be connected to VEGATOR 536 to deactivate the connected signal lamp (horn etc.) in case of a level alarm (e.g. reaching of the max. permissible level). This key can deactivate a level alarm. In case of failure (e.g. line break) the alarm is not deleted.

When the key-switch is connected, the fail safe relay has the same function as the level relay, however the fail safe relay can be reset by pushing the reset of alarm functions key.

If an acoustic warning system is activated when max. level is reached, it can be switched off by pushing the reset of alarm functions key. The second output (level relay) signals to the process control system when max. level is reached.

Note

If strong electromagnetic interferences are expected, we recommend using screened cable. The screening must be earthed at one end on the sensor side. The following illustrations show the currentless condition.

Module with multipoint connector acc. to DIN 41 612 for carrier (rear view)

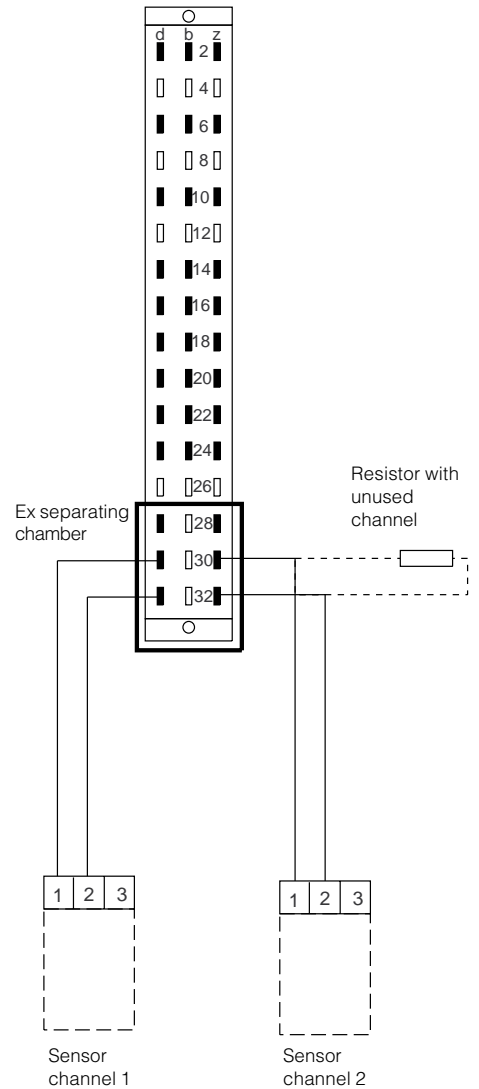

VEGATOR 536 Ex

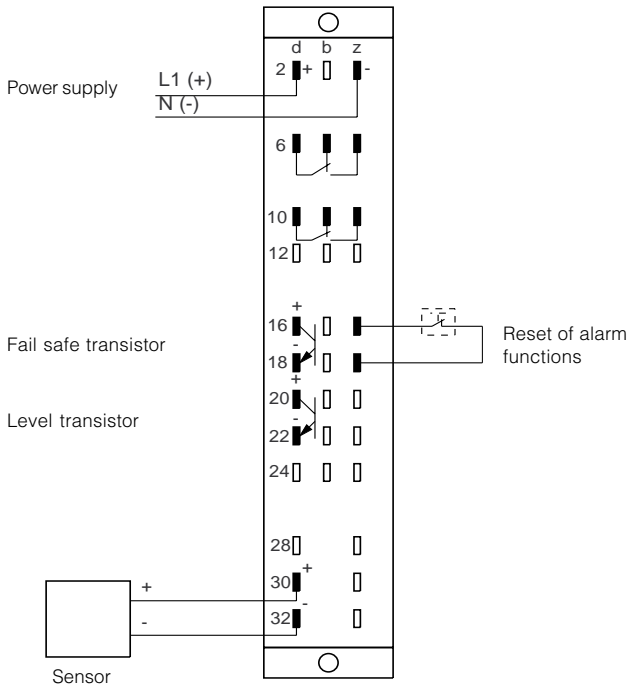

VEGATOR 537 Ex

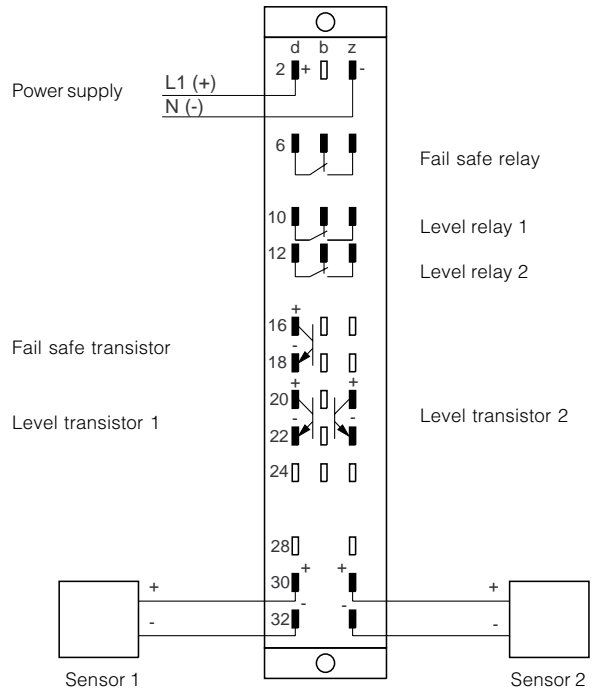

VEGATOR 636 Ex

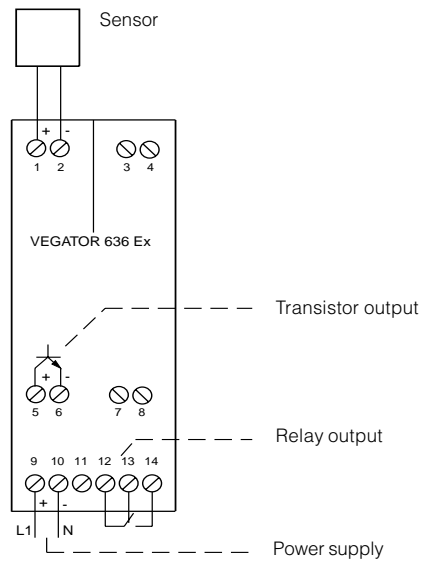

Level and Pressure
VEGA Grieshaber KG Am Hohenstein 113 D-77761 Schiltach Phone +49 7836 50-0 Fax +49 7836 50201 e-mail info@de.vega.com www.vega.com

VEGA - Your worldwide sales and service partner

- | | | |
|--------------------|---------------|-----------------------|
| Argentina | Great Britain | Poland |
| Australia | Hong Kong | Portugal |
| Austria | Hungary | Romania |
| Belgium/Luxembourg | India | Singapore |
| Brazil | Indonesia | Slovakia |
| Bulgaria | Iran | Slovenia |
| Chile | Israel | Southern Africa |
| China | Italy | Spain |
| Columbia | Japan | Sweden |
| Croatia | Korea | Switzerland |
| Czech Republic | Lithuania | Taiwan |
| Denmark | Malaysia | Thailand |
| Egypt | Netherlands | Turkey |
| Finland | New Zealand | USA/Canada/Mexico |
| France | Norway | United Arab. Emirates |
| Germany | Peru | Venezuela |
| Greece | Philippines | |

Detailed information on our homepage www.vega.com

