



Low Volume / All Metal Variable Area Overview Meters / Monitors



measuring
•
monitoring
•
analysing



- Flow rates:
Water:
0.3-3 L/h to 10-100 L/h
Air:
5-50 L_N/h to 340-3400 L_N/h
- Accuracy:
Class 2.5 according to VDI
- p_{max} 130 bar; t_{max} 180 °C
- Connection: ¼ NPT female
- Material: stainless steel
- Mechanical indicator
(limit contacts)
- Bar graph indicator
(analogue output)



KOBOLD offices exist in the following countries:

ARGENTINA, AUSTRIA, BELGIUM, BRAZIL, CANADA, CHINA,
FRANCE, GERMANY, GREAT BRITAIN, ITALY, MEXICO, NETHER-
LANDS, PERU, POLAND, SWITZERLAND, USA, VENEZUELA

KOBOLD Messring GmbH
Nordring 22-24
D-65719 Hofheim/Ts.
☎ +49(0)6192 299-0
Fax +49(0)6192 23398
E-Mail: info.de@kobold.com
Internet: www.kobold.com

Model:
KDK



Description

The KOBOLD flow meter model KDK for liquids, gases and vapours is an all-metal flow meter that operates on the suspended float principle. Due to its very rugged construction, it is suited to difficult applications. The elevation of the float (which depends on the flow) is transferred by magnetic means to the indicator scale. The installation position must be vertical and the direction of flow must be from bottom to top.

KDK versions

KDK-12...: with mechanical indicator (with a maximum of two contacts as an option)

KDK-22...: with bargraph and analogue output 4–20 mA

Model: KDK-12...analogue indication

Mechanical, easy to read, local indication. The float is magnetically coupled to the scale. No auxiliary power is needed

Adjusting valve (including)

The needle valve is fitted as standard on the inlet. It can also be fitted on the outlet on request.

Technical Details

Accuracy class: 2.5 according to VDI / VDE guideline 3513, sheet 2

Mechanical connection: 1/4 NPT female (at the back)
other connections upon request
For example Ermeto, Swagelok

Max. operating pressure: 130 bar
> 130 bar upon request

Materials:

Measuring tube:	Stainless steel 1.4571
Head/base:	Stainless steel 1.4581
Float:	Stainless steel 1.4571
Fittings:	Stainless steel 1.4571
Gaskets:	PTFE
Float stop:	PFA

Protection: IP 65 (accord. to EN 60529)

Temperature:

Environment:	- 25 to +60 °C
Medium:	- 80 to +180 °C

(without supplementary devices)
>150 °C please specify,
valve adjusting knob is then made of aluminium

Supplementary electrical devices:

limit contact(s) Model: KDK..K

One or two contacts may be fitted. These contacts are slotted proximity switches. Both contacts can be moved across the entire measuring range, The set values are shown on the indicator.

An isolation and switch unit is required to operate one or both contacts (type REL-6000 see Z2 Accessories brochure).

Nominal voltage:	8 V _{DC}
Current consumption:	≥ 3 mA or ≤ 1 mA (depending on the output state)
Electrical characteristic values:	according to DIN 19234 and NAMUR
Temperature:	
ambient	- 25 to +60 °C
Medium:	- 80 to +180 °C (at Tu < 40 °C)
Protection:	IP 65 according to EN 60529

Model: KDK..22 bargraph with analogue output

The current output supplies a linear current of 4 to 20 mA in two-wire format that is proportional to the actual flow rate. Using state-of-the-art magnetic field sensors and reliable micro-electronics, a rugged component has been developed that is fitted without mechanical transmission in the indicator. The sensors are temperature compensated.

- 10-bit linearization
- Determining the position of the float without hysteresis
- Indicator self-test during initial operation
- Operation with standard power supply units

Technical Details

Connection technology:	two-wire circuitry
Power supply:	16 to 30 V _{DC}
Current output:	4 to 20 mA
Temperature effect:	< 10µA/°K of measured value
Temperature:	
environment	- 25 to +60 °C
Medium:	- 50 to +155 °C
Ball:	- 40 to +50 °C



Mechanical supplementary devices (option)

Differential pressure controller

A differential pressure controller can be fitted to maintain constant flow with fluctuating operating pressure.

Upstream pressure controller

The flow rate remains constant with

- variable upstream pressure and
- constant downstream pressure

Downstream pressure controller

The flow rate remains constant with

- constant upstream pressure and
- variable downstream pressure

Important:

Differential pressure controllers are **not** pressure-reducing valves

Technical Details

- Max. pressure: 16 bar (brass)
25 bar (stainless steel)
(option 64 bar)
- Max. temperature: 80 °C (option 150 °C)
- Max. flow rate: 4000 L/h air or 160 L/h water
- Connection: 1/4 NPT female
or Ermeto, Swagelok
- Materials: brass or stainless steel

Controller characteristic

Upstream pressure · Model: RE, NRE

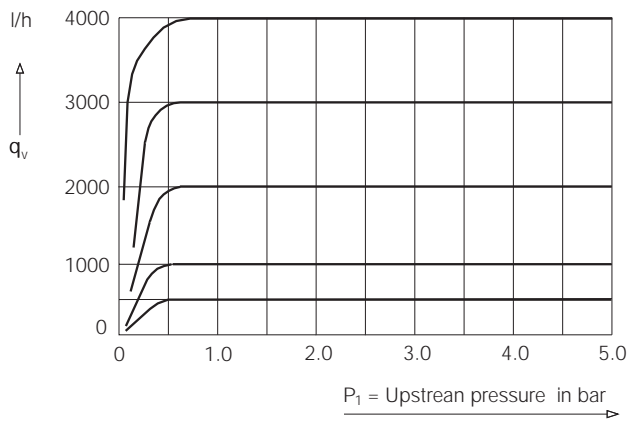

Controller characteristic

Downstream pressure · Model: RA, NRA

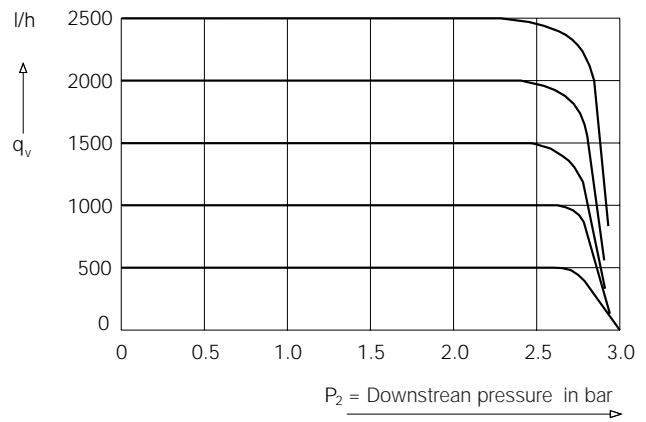

Upstream pressure controller	Max. Flow		Min. upstream pressure bar
	Water L/h	Air L/h	
RE 1000	40	1000	0.5
RE 4000	160	4000	1
NRE 800		800	0.2

Downstream pressure controller	Max. Flow		P1* min. differential pressure i. bar
	Water L/h	Air L/h	
RA 1000	40	1000	0.4
RA 2500	160	2500	0.8
NRA 800		800	0.15

*P1 is the differential pressure between upstream and downstream pressures (upstream pressure must be greater than downstream pressure)



Dimensions

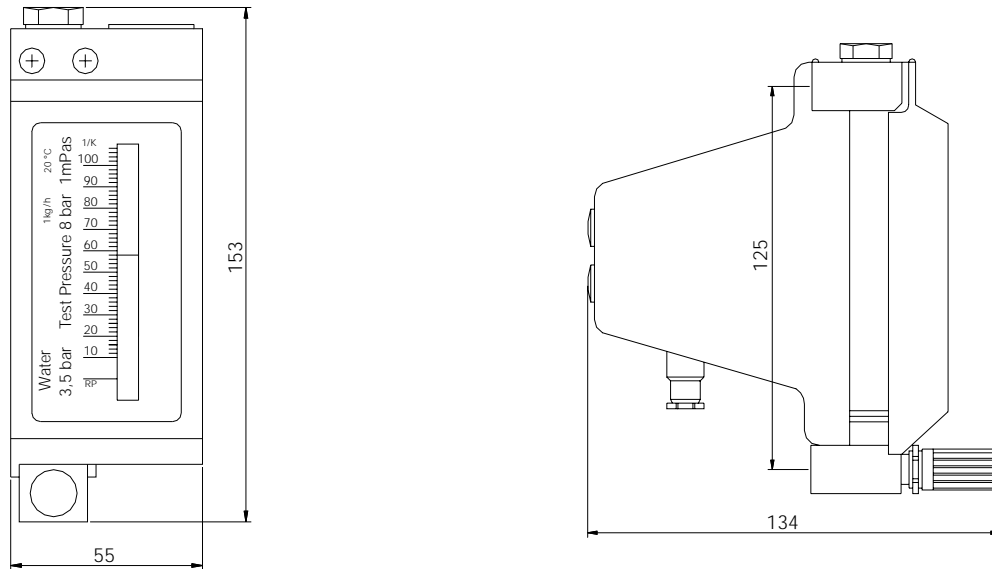

Order Details

Model: KDK-12... with mechanical indicator (Example: KDK-1202H 00 E1)

Measuring range water (at 20°C)		Measuring range air (at 1.013 bar abs., 20°C)		Contacts option	Controller option (see page 27 for data)
L/h	Order number	L _N /h	Order number		
-	-	5 - 50	KDK-1201L...	..00.. = without ..K1.. = 1 contact ..K2.. = 2 contacts	...00= without ...E1= RE1000 ...A1= RA 1000 ...NE= NRE 800 * ...NA= NRA 800 *
0.3 - 3	KDK-1202H...	10 - 100	KDK-1202L...		
0.5 - 5	KDK-1203H...	15 - 150	KDK-1203L...		
1 - 10	KDK-1204H...	40 - 400	KDK-1204L...		
2.5 - 25	KDK-1205H...	80 - 800	KDK-1205L...		
4 - 40	KDK-1206H...	125 - 1250	KDK-1206L...		
6 - 60	KDK-1207H...	200 - 2000	KDK-1207L...		...E2= RE 4000 ...A2= RA 2500
8 - 80	KDK-1208H...	250 - 2500	KDK-1208L...		
10 - 100	KDK-1209H...	340 - 3400	KDK-1209L...		

Options

- Valve on outlet
- Titanium float (for flow rates lower than standard rates)
- Ermeto screwed fitting 6 or 8 mm
- Swagelok

* for air only to max. 800 L_N/h

Model: KDK-22... with bar graph and 4-20 mA analogue output 4-20 mA
(Example: KDK-2202H A4 00)

Measuring range water (at 20°C)		Measuring range air (at 1.013 bar abs., 20°C)		Analogue output	Controller option (see page 27 for data)
L/h	Order number	L _N /h	Order number		
-	-	5 - 50	KDK-2201L...	..A4.. = 4-20 mA	...00= without ...E1= RE1000 ...A1= RA 1000 ...NE= NRE 800 * ...NA= NRA 800 *
0.3 - 3	KDK-2202H...	10 - 100	KDK-2202L...		
0.5 - 5	KDK-2203H...	15 - 150	KDK-2203L...		
1 - 10	KDK-2204H...	40 - 400	KDK-2204L...		
2.5 - 25	KDK-2205H...	80 - 800	KDK-2205L...		
4 - 40	KDK-2206H...	125 - 1250	KDK-2206L...		
6 - 60	KDK-2207H...	200 - 2000	KDK-2207L...		...E2= RE 4000 ...A2= RA 2500
8 - 80	KDK-2208H...	250 - 2500	KDK-2208L...		
10 - 100	KDK-2209H...	340 - 3400	KDK-2209L...		

Options

- Valve on outlet
- Titanium float (for flow rates lower than standard rates)
- Ermeto screwed fitting 6 or 8 mm
- Swagelok

* for air only to max. 800 L_N/h